

SPECIFICATIONS Mycenter-HX500iG

	Mycenter-HX500iG #40	Mycenter-HX500iG #50
Table		
Table Size	500 x 500mm (19.7" x 19.7")	
Table Indexing	0.001 Degree (4th Axis)	
Tapped Hole (Size x Qty)	M16 x 2.0 x 24	
Max. Table Load	800kg (1,760 lbs.)	
Max. Workpiece Dia.	Ø800mm (Ø31.5")	
Max. Workpiece Height	1,100mm (43.3")	

Travels		
X-Axis Travel	870mm (34.3") / Twin Ballscrew Design	
Y-Axis Travel	800mm (31.5") / Twin Ballscrew Design	
Z-Axis Travel	930mm (36.6")	
B-Axis Travel	0 to 360 Degrees Full 4th Axis	
Table Surf. to Spindle Center	50 ~ 850mm (2.0" ~ 33.5")	
Table Center to Spindle Nose	140 ~ 1,070mm (5.5" ~ 42.1")	60 ~ 990mm (2.4" ~ 39.0")

Spindle		
Spindle Taper	#40 NST (HSK-A63 Option)	#50 NST (HSK-A100 Opt.)
Spindle Speed	20 ~ 20,000min ⁻¹	35 ~ 12,000min ⁻¹ (8,000min ⁻¹ Opt.)
Drive Method	Gear Drive, 4-Step	
Maximum Spindle Torque	266.4 N·m (196.5 ft·lbs)	585.9 N·m (432.1 ft·lbs)
Spindle Motor	22kW (30HP AC/15 min) 15kW (20HP AC/Cont.)	40kW (53HP AC/15 min) 22kW (30HP AC/Cont.)

Feed		
Rapid Feed X,Y,Z	60m/min (2,362ipm)	
Cutting Feed Rate X,Y,Z	60m/min (2,362ipm)	
Rapid Feed (B-Axis)	43,200 deg/min (120min ⁻¹)	

APC		
Number of Pallets	2	
APC Change Time	8.8 seconds	

ATC		
Tool Storage Capacity	50 Tools (Opt. 100, 150, 200, 300)	62 Tools (Opt. 112, 122, 162, 212)
Tool Selection Method	Random bi-directional, Fixed Pot	
Tool Holder Style	CT (BT) 40 (HSK-A63 Opt.)	CT (BT) 50 (HSK-A100 Opt.)
Max. Tool Dia.	Ø95mm (Ø3.7") / Ø170mm (Ø6.7")	Ø125mm (Ø4.9") / Ø300mm (Ø11.8")
Max. Tool Length	600mm (23.6")	
Max. Tool Weight	10kg (22 lbs.)	30kg (66 lbs.)
Tool to Tool	1.3 seconds	2.1 seconds
Chip to Chip	3.8 seconds, min.	4.8 seconds, min.

Utilities		
	55KVA, 200v AC, 3 Phase	75KVA, 200v AC, 3 Phase
Air Requirement	0.5 MPa, 410L / min (90psi, 14cfm)	

Machine Dimensions		
Required Space (W x D)	3,585 x 4,957mm (141.1" x 195.2")	3,620 x 4,957mm (142.5" x 195.2")
Machine Height	3,178mm (125.1")	3,499mm (137.8")
Machine Net Weight	16,100kg (35,420 lbs.)	16,500kg (36,300 lbs.)

Control		
	Arumatik®-Mi	

Available Options

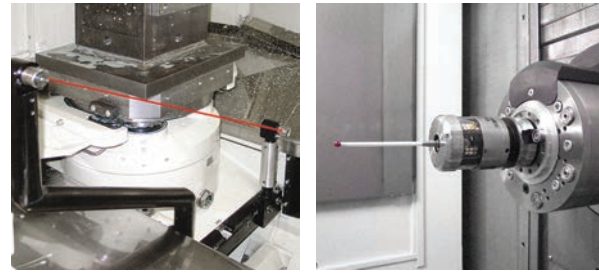

Spindle and Tool Probes

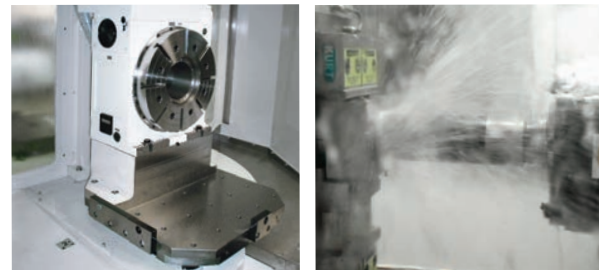

Field Retrofittable 5th Axis Rotary Tables (available on both pallets)

Up to 1000psi Coolant Thru the Spindle Available



- Machine Monitoring Software Suite
- MTConnect Ready Adaptor

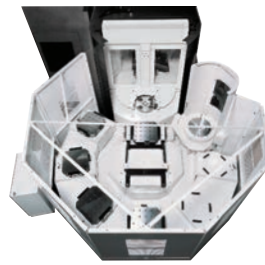

Field Expandable Multi-Pallet Systems



Kitamura Machinery Co., Ltd. (Headquarters)
TEL: +81.766.63.1100 FAX: +81.766.63.1128
www.kitamura-machinery.co.jp

Kitamura Machinery of U.S.A., Inc. (Chicago)
TEL: +1.847.520.7755 FAX: +1.847.520.7763
www.kitamura-machinery.com

Kitamura Machinery GmbH (Düsseldorf)
TEL: +49.211.65.6077 FAX: +49.211.904.7916
www.kitamura-machinery.eu



MYCENTER®

HX500iG

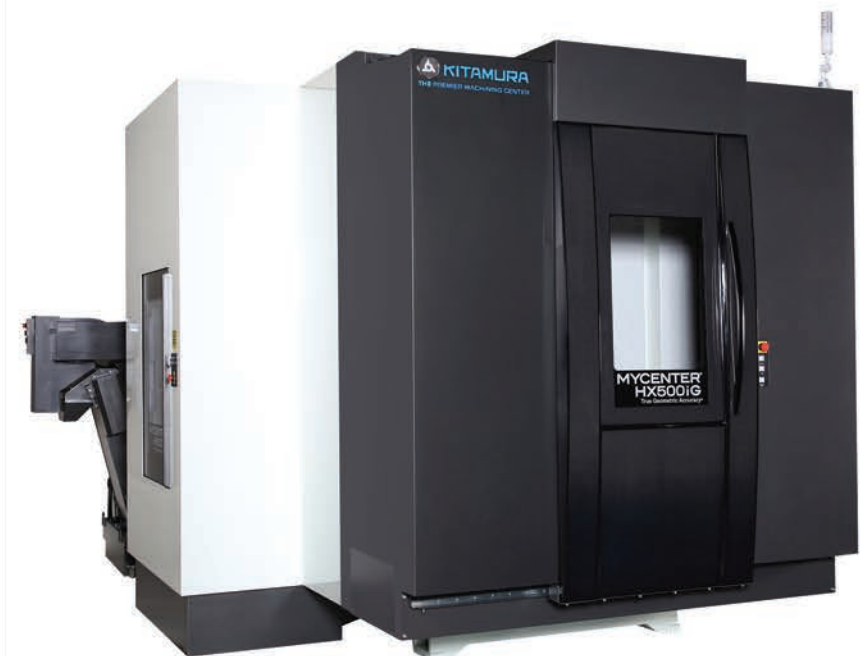
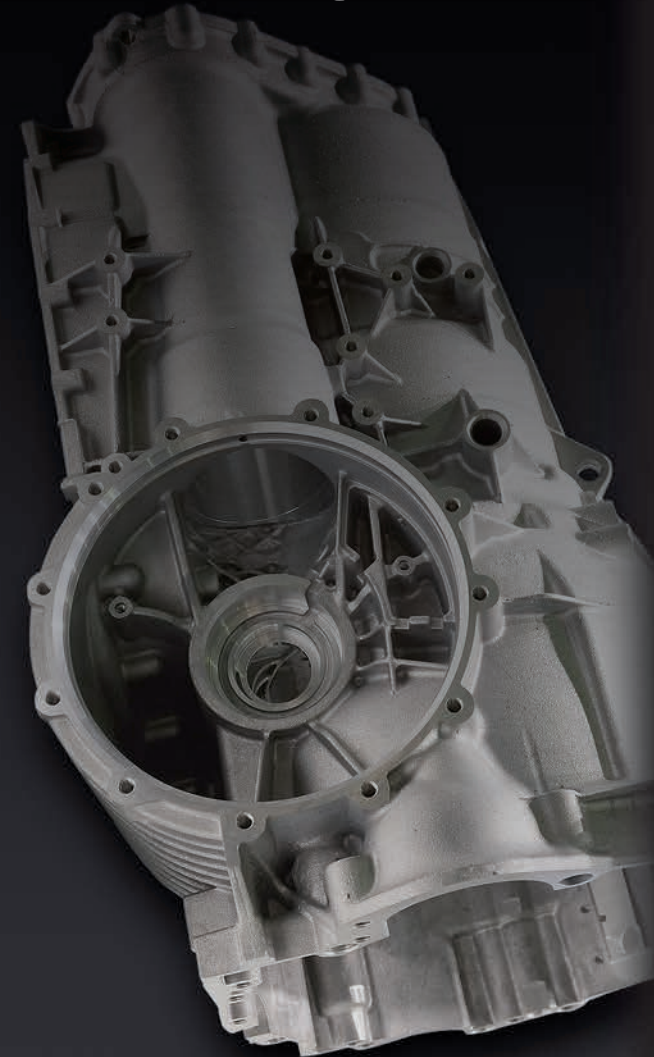

HORIZONTAL MACHINING CENTER

SIMPLIFY THE COMPLICATED

HX500iG The 500mm performance package designed to handle today's toughest metal cutting demands

Optimum rigidity and higher cutting accuracy for difficult to machine materials

- Field expandable 2-station APC with high speed 4th axis rotary table with rotary scale. Integral drive motor driven with rapids 43,200deg/min (120min⁻¹)
- Ultra-high-speed rapid/cutting feeds, 60m/min (2,362ipm) on solid box ways
- Standard 50T (#40) and 62T (#50) fixed pot ATCs with ultra-high speed tool change, T-T 1.3/2.1 seconds
- Powerful dual contact, 4-step gear driven spindles. 20,000min⁻¹ (#40) or 12,000min⁻¹/8,000min⁻¹ Opt. (#50). HSK spindle options available.
- Ballscrew cooling and fine resolution linear scale feedback in all axes (X,Y,Z)
- Standard 220psi coolant thru the spindle and wash coolant
- Double decker style chip conveyor and filtration system with conveyor reverse switch

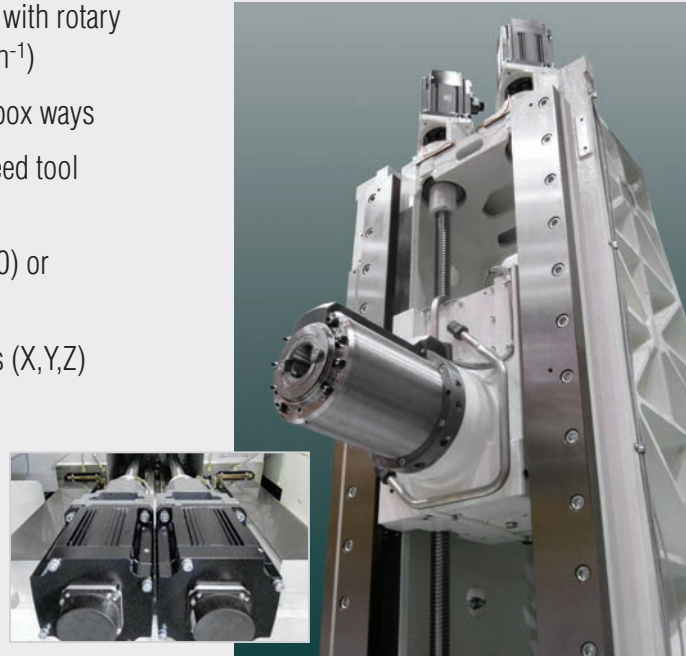

Patented Twin Ballscrew & dual feedback technology since 1999 provides the stability to support and move large, heavy masses at higher speeds.

Kitamura castings provide critical design benefits:

- Premium grade Meehanite cast iron
- Solid column construction
- Hand-scraped surfaces for absolute perfect fit with no gaps
- Solid Induction Hardened Boxways produced at our factory in Japan
- Zero overhang for guaranteed static accuracies of +/- 0.002mm (+/-0.000079") / full stroke



Induction hardened solid box guideways with linear scale feedback on all axes with twin ballscrew design in X & Y axes.

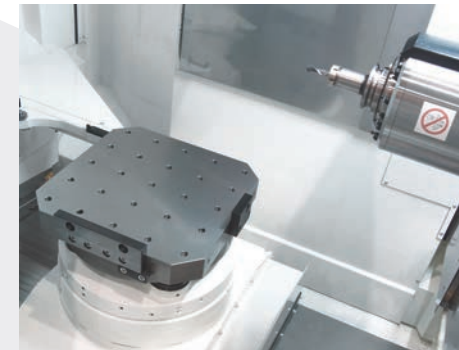

High Speed B-Axis - Integral Drive Motor Driven 43,200deg/min (120min⁻¹) Rotation.

- Positioning Accuracy ±2 arc sec
- High resolution built-in Heidenhain rotary encoder
- Zero backlash
- Dramatically faster indexing time reduces out of cut time and increases the amount of material removed in milling applications. Turning is possible with "Fastest in class"

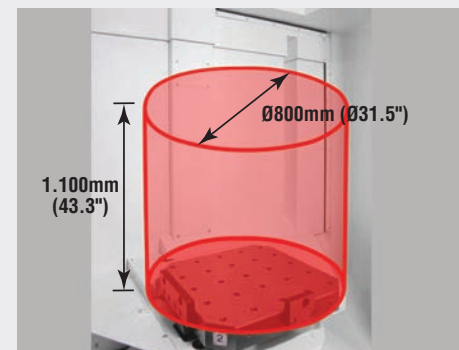

Generous Work Envelope.
Ø800mm (Ø31.5") x 1,100mm (43.3") H. Standard 2-APC system and full 4th axis offer smart fixturing and work holding options. An additional 5th axis can be added to BOTH pallets in the field for ultimate flexibility and less handling of your more complex parts.



Pioneering Icon CNC Operation with Interactive Touchscreen Display Technology

Arumatik® Mi

- 67 Million pulse encoder technology with 8,192 block look-ahead processing speeds
- Software upgrades throughout the life of the control
- Fanuc user-friendly
- Completely customizable and expandable user experience
- Video Guidance and visual programming screens
- Anywhere-Remote® E-Mail status updates

Positioning Accuracy +/-0.002mm (+/-0.000079") / Full Stroke

World renowned JAPANESE

The latest in control technology with a focus on ease of use for the operator



Customizable Icon Screen. Advanced touch screen capabilities with user customized main menu touch screen and a variety of visual programming screens and functions that offer the operator faster and easier methods of part set-up and processing.

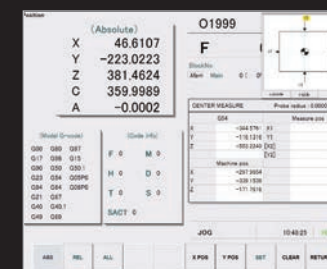

Work Set Assistance. Set-up work offsets with just a few keystrokes. Four types of measurements are possible. Edge side measure, center measure, 3 point diameter center measure and corner measure if angular.

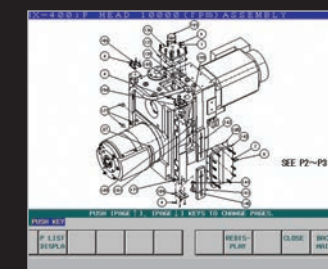

Maintenance Support Function. Kitamura's Maintenance Support Function Offers operator convenience in displaying methods of machining maintenance, repair and parts support on the NC Screen

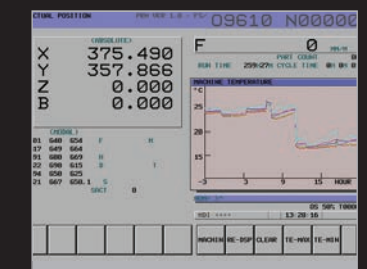

Intelligent Advanced Control System. Controls the effects of heat displacement in order to ensure continuous accuracy in machining. Minimizes head displacement to less than +/-5 microns. 6 sensors positioned on the machine measure and monitor temperature of machine and compensation guarantees positioning accuracy of +/-0.002mm (+/-0.000079") / Full stroke. Kitamura patented system since 1998.

*Daily Thermal Graphic Display

Repeatability +/-0.001mm (+/-0.000039")

design, engineering and manufacture since 1933